

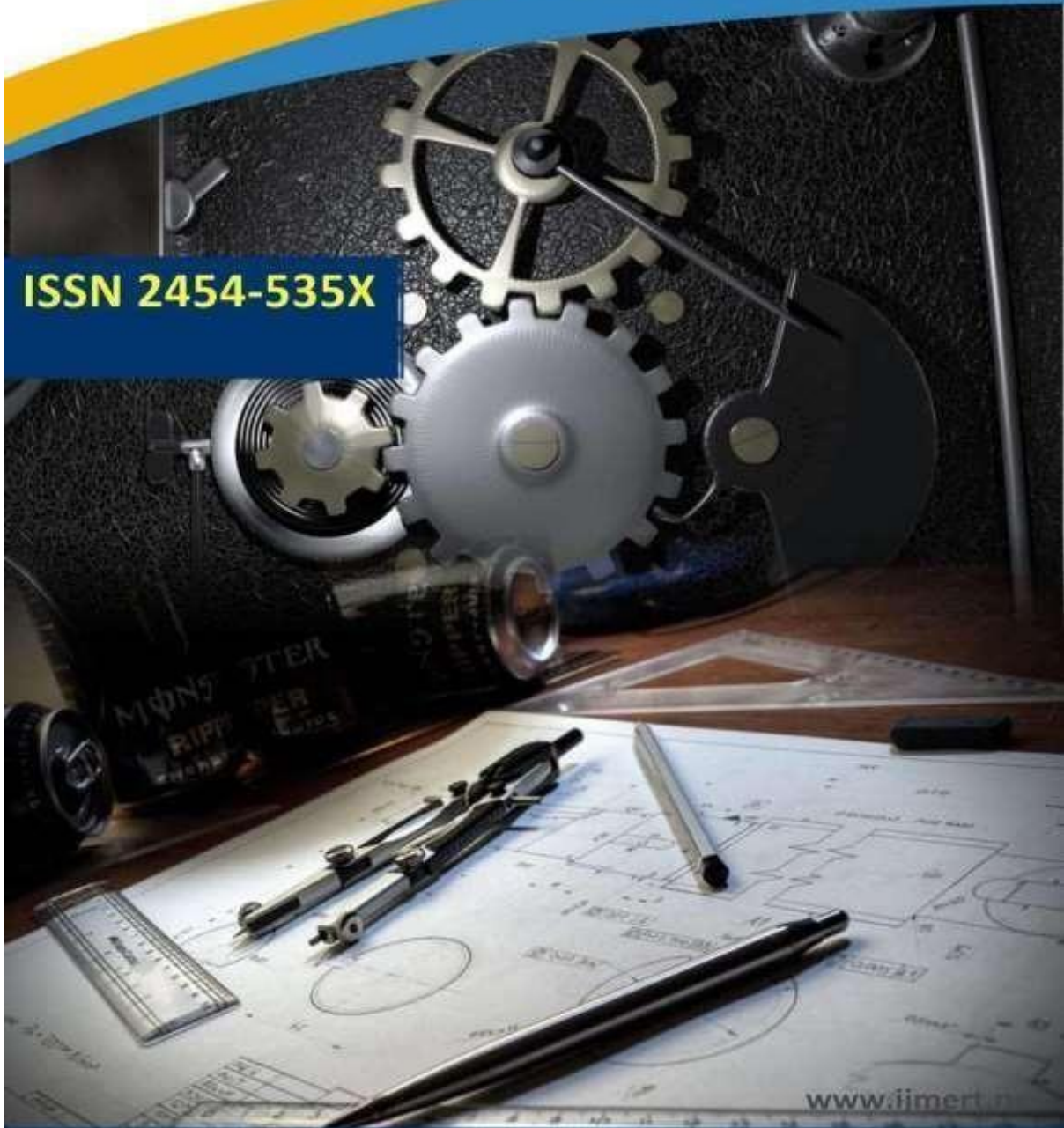

International Journal of
Mechanical Engineering Research and Technology

ISSN 2454-535X



www.ijmert.net

Email ID: info.ijmert@gmail.com or editor@ijmert.net

POWER UP PASS

1.T. SWATHI, 2. K. SAIKIRTHANA, 3. K. KEERTHANA, 4. G. HARSHITHA.

1.ASSISTANT PROFESSOR, 2,3&4.UG SCHOLAR

DEPARTMENT OF ECE, MALLA REDDY ENGINEERING COLLEGE FOR WOMEN,
HYDERABAD

ABSTRACT:

The scope of the identified problem is expansive, encompassing the increasing reliance on electronic devices and the growing demand for efficient charging solutions. The ubiquity of smartphones, tablets, and other portable gadgets has given rise to a pressing need for dedicated charging infrastructure. While electric vehicle charging stations have proliferated, there remains a conspicuous gap in addressing the unique charging requirements of everyday electronic devices. This gap poses a challenge for users who seek a reliable and convenient means to charge their devices on the go, hindering the seamless integration of technology into their daily routines. The problem scope extends to the absence of a streamlined and user-friendly charging solution tailored specifically for electronic gadgets. The current limitations in charging infrastructure prevent users from maximizing the potential of their devices without disruptions. The identified problem

is not confined to a specific demographic; instead, it resonates with a broad spectrum of users who navigate their daily lives with an array of electronic devices. The lack of a dedicated charging system for these devices limits accessibility and convenience, necessitating an innovative solution. In response to this problem scope, "PowerUp Pass" aims to redefine the charging experience for electronic gadgets, presenting an opportunity for a comprehensive solution. By focusing on user-friendly mobile app interactions, seamless booking of charging slots, and efficient payment mechanisms, the proposed system endeavors to fill this gap in the charging infrastructure, offering users a more organized and predictable approach to charging their devices on the go. The envisioned solution is not just confined to technical intricacies but extends to creating a paradigm shift in how users perceive and engage with charging solutions. The integration of technology components, including nodemcu, relay, and

OLED display, further amplifies the potential impact of "PowerUp Pass" within the broad problem scope. Ultimately, the problem scope reaches beyond the technical realm, delving into the realms of user experience, accessibility, and the seamless integration of charging solutions into the fabric of daily life. Addressing this comprehensive scope will contribute to a more connected, technologically empowered, and user-centric society

INTRODUCTION

"PowerUp Pass" emerges as a revolutionary solution, bridging the gap between the ubiquitous need for on-the-go charging of electronic gadgets and the advanced technology employed in electric vehicle charging stations. Unlike conventional charging solutions, this innovative platform offers users the convenience of booking slots for charging their electronic devices through a user-friendly mobile application. The seamless user experience allows individuals to not only reserve a charging slot but also make payments based on both the duration of the charging time and the electricity consumed during the process



Fig : Charging Station

Central to the functionality of PowerUp Pass are key components such as the nodemcu, relay, and an OLED display. The nodemcu serves as the central intelligence, facilitating smooth communication between the user's mobile app and the charging station. The relay, acting as a power controller, ensures the secure and efficient flow of energy to the charging ports. The OLED display plays a pivotal role in providing real-time information to users, including details such as the amount spent, remaining charging time, and the charging percentage. PowerUp Pass marks a significant advancement in enhancing the accessibility and convenience of charging solutions for everyday electronic devices. By integrating state-of-the-art technologies

into a user-friendly mobile application and incorporating essential components like nodemcu, relay, and OLED, PowerUp Pass not only simplifies the charging process but also redefines the user experience in the realm of electronic gadget charging. This introduction sets the stage for a deeper exploration of PowerUp Pass, delving into its intricacies and highlighting the transformative impact it holds in reshaping the landscape of on-the-go electronic device charging.

LITERATURE SURVEY

The literature survey explores the existing body of knowledge surrounding on-the-go electronic device charging solutions and identifies key insights that inform the development of "PowerUp Pass." Studies in the field highlight the increasing reliance on electronic devices in daily life, emphasizing the need for accessible and efficient charging infrastructure. Existing research reveals a gap in dedicated charging solutions for everyday gadgets, contrasting with the prevalence of electric vehicle charging stations. Literature also underscores the challenges users face in finding reliable and convenient on-the-go charging options, emphasizing the significance of user-friendly interfaces and

streamlined processes. Technological integration is a focal point in the literature, with studies showcasing the role of components like nodemcu, relay, and OLED displays in optimizing charging systems. The importance of sustainable charging practices is highlighted, aligning with global initiatives for responsible resource usage. Furthermore, research emphasizes the role of mobile apps in enhancing user experience and convenience, providing valuable insights into the design and functionality aspects that should be considered in the development of "PowerUp Pass." The literature survey establishes a foundation for the proposed system, drawing from existing research to address the identified problem scope and contribute to the evolving landscape of on-the-go electronic device charging. The literature survey delves into the realm of on-the-go electronic device charging, shedding light on the burgeoning demand for efficient charging infrastructure amid the escalating reliance on electronic gadgets in daily life. Extant studies underscore the pressing need for accessible and user-friendly charging solutions, a demand that stands in stark contrast to the proliferation of electric

vehicle charging stations. Researchers highlight the notable gap in dedicated charging infrastructure for everyday gadgets, underscoring the necessity for streamlined processes and intuitive interfaces in addressing users' evolving needs. The literature extensively discusses technological integration as a cornerstone in the evolution of charging systems. Components such as nodemcu, relay, and OLED displays emerge as pivotal elements in optimizing charging efficiency and user experience. Sustainable charging practices garner attention in the literature, aligning with global sustainability initiatives and emphasizing responsible resource utilization. Moreover, research accentuates the pivotal role of mobile applications in enhancing user convenience and interaction, offering valuable insights into design considerations and functional requirements pivotal for "PowerUp Pass" development. Through synthesizing existing research, the literature survey lays the groundwork for "PowerUp Pass," drawing on insights to bridge the identified gap in on-the-go electronic device charging. By leveraging technological advancements and prioritizing user-centric design principles,

the proposed system aims to redefine the charging experience, catering to the diverse needs of contemporary gadget users. The literature survey thus serves as a catalyst for innovation, shaping the trajectory of electronic device charging and contributing to the ongoing evolution of charging solutions in the digital era.

Proposed Solution:

The proposed system, "PowerUp Pass," represents a comprehensive solution to address the identified problem scope of the lack of streamlined and user-friendly charging infrastructure for everyday electronic devices. This innovative system is designed to revolutionize the landscape of on-the-go electronic device charging, offering a host of features and functionalities that enhance accessibility, convenience, and user experience.

1. User-Friendly Mobile App: "PowerUp Pass" introduces a user-friendly mobile app interface, allowing users to effortlessly reserve charging slots, make payments, and monitor charging status. The intuitive design ensures a seamless and engaging experience for users.

2. Dedicated Charging Infrastructure: The system establishes a dedicated charging infrastructure tailored specifically

for electronic gadgets, filling the existing gap in charging solutions and providing users with a reliable means to charge their devices on the go.

3. Seamless Booking and Payments:

Through the mobile app, users can conveniently book charging slots, enabling a more organized and predictable approach to charging. Payments for both the charging time and electricity consumed are seamlessly integrated into the booking process.

4. Technological Components: The integration of key technological components, including nodemcu, relay, and an OLED display, forms the backbone of "PowerUp Pass." Nodemcu facilitates communication, relay controls power flow, and the OLED display provides real-time information to users.

5. Real-Time Information Display: The OLED display presents users with crucial real-time information, including the amount spent, remaining charging time, and charging percentage. This enhances transparency and empowers users to make informed decisions about their charging needs.

6. Enhanced Accessibility: "PowerUp Pass" ensures enhanced accessibility for a

broad spectrum of users who rely on electronic gadgets, catering to professionals, students, and individuals from diverse backgrounds.

7. Sustainable Charging Practices: By allowing users to pay for both the charging time and the electricity consumed, "PowerUp Pass" encourages sustainable charging practices, aligning with the global emphasis on responsible resource usage and environmental consciousness.

8. Efficient Resource Utilization: The system optimizes resource utilization through the efficient control of power flow to charging ports, ensuring a secure and efficient charging process for electronic devices.

9. Paradigm Shift in User Experience: "PowerUp Pass" contributes to a paradigm shift in how users perceive and engage with charging solutions, emphasizing a user-centric design that aligns with the evolving needs of the digital era.

10. Broad Applicability and Technological Empowerment: With its innovative approach and technological integration, "PowerUp Pass" is poised to empower users by providing a solution that not only meets their charging needs but also contributes to a more connected, efficient,

and technologically empowered society. The proposed system, "PowerUp Pass," is a forward-thinking solution designed to fill the existing gap in on-the-go electronic device charging. By combining a user-friendly mobile app, dedicated charging infrastructure, key technological components, and sustainable practices, the system aims to redefine the charging experience, offering users a solution that seamlessly integrates into their daily lives.

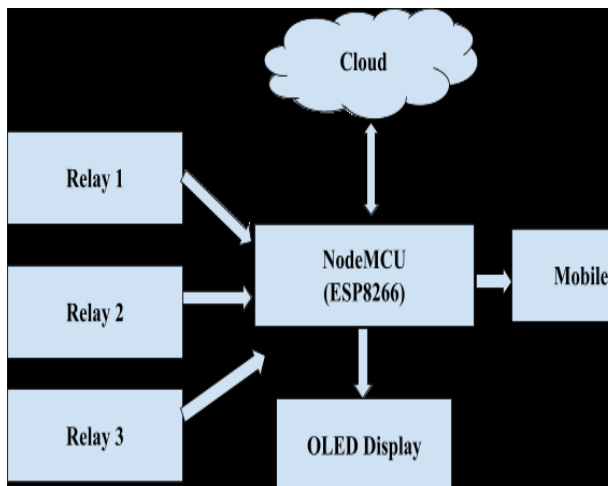

Fig: Block Diagram

METHODOLOGY

The methodology for developing "PowerUp Pass" follows a systematic and informed approach, drawing insights from the comprehensive literature survey conducted. The initial phase involves a meticulous requirement analysis, synthesizing the identified challenges in on-the-go electronic device

charging and the desired features derived from existing research. Stakeholder engagement is crucial during this phase to ensure the system addresses diverse user needs effectively. Following this, the selection and integration of technological components, including nodemcu, relay, and OLED displays, are prioritized, leveraging insights from literature emphasizing their pivotal roles in optimizing charging systems. The system's architecture is meticulously designed to incorporate these components seamlessly, ensuring the efficient control of power flow and real-time information display, aligning with the technological integration highlighted in the literature. The development of a user-friendly mobile app takes center stage, with an emphasis on insights gleaned from the literature regarding the significance of streamlined processes and intuitive interfaces. Sustainability principles derived from the literature guide the incorporation of features encouraging responsible resource usage. Usability testing and continuous improvement, based on feedback from potential users, play a critical role in refining the user interface and overall system functionality. The methodology also includes a pilot

deployment with select users to gather real-world feedback and identify areas for improvement before a full-scale implementation. Rigorous testing and quality assurance measures are implemented to ensure the functionality, security, and reliability of "PowerUp Pass." The methodology synthesizes findings from the literature survey, leveraging insights to inform the development process systematically. By combining technological integration, user-centric design principles, and sustainability considerations, the methodology aims to deliver a transformative on-the-go electronic device charging solution in the form of "PowerUp Pass"

CONCLUSION In this paper, MCS for the EVs has been modelled at the system level. The purpose of designing the MCS is to coordinate the flow of power between the grid and the batteries in a controlled fashion using FLC. A suitable algorithm has been designed which takes into consideration and SOC of the batteries. EVs batteries are not discharged beyond the owner's preferred SOC limit and .An algorithm for distribution of power among the CS and the batteries is also developed. The complete model is tested on

a typical distribution grid of a city. MCS is capable of handling different scenario of EVs arrival and departure during peak and off-peak hours. The dynamic load profile is obtained for a particular node and used to test the proposed model. It is verified that the proposed MCS can stabilize the grid by valley filling and peak shaving.

REFERENCES

- [1] J. Tomic and W. Kempton, "Using fleets of electric-drive vehicles for grid support," *J. Power Sources*, vol. 168, pp. 459–468, 2007.
- [2] W. Kempton and J. Tomic, "Vehicle-to-grid power implementation: From stabilizing the grid to supporting large-scale renewable energy," *J. Power Sources*, vol. 144, pp. 280–294, 2005.
- [3] C. Guille and G. Gross, "A conceptual framework for the vehicle-to-grid (V2G) implementation," *Energy Policy*, pp. 4379–4390, 2009.
- [4] W. Kempton and J. Tomic, "Vehicle-to-grid power fundamentals: Calculating capacity and net revenue," *J. Power Sources*, vol. 13, no. 144, pp. 268–279, Jun. 2005.
- [5] Y. Ma, T. Houghton, A. Cruden, and D. Infield, "Modeling the benefits of vehicle-to-grid

- technology to a power system,” IEEE Trans. Power Syst., vol. 27, no. 2, pp. 1012–1020, May 2012.
- [6] W. Kempton, V. Udo, K. Huber, K. Komara, S. Letendre, S. Baker, D. Brunner, and N. Pearre, “A test of vehicle-to-grid (V2G) for energy storage and frequency regulation in the PJM system,” Report of the Mid-Atlantic Grid Interactive Car Consortium (MAGIC), Nov. 2008 [Online]. Available: <http://www.udel.edu/V2G/resources/test-v2g-inpjm-jan09.pdf>
- [7] S. Han, S.Han, and K.Sezaki, “Development of an optimal vehicle-to-grid aggregator for frequency regulation,” IEEE Trans. Smart Grid, vol. 1, no. 1, pp. 65–72, Jun. 2010.
- [8] K.C.Nyns, E.Haesen, and J.Driesen, “The impact of charging plug-in hybrid electric vehicles on a residential distribution grid,” IEEE Trans. Power Syst., vol. 25, no. 1, pp. 371–380, Feb. 2010.
- [9] A. Masoum, S.Deilami, P. Moses, and A. Abu-Siada, “Impacts of battery charging rates of plug-in electric vehicle on smart grid distribution systems,” Proc. Innovative Smart Grid Technologies Conference Europe (ISGT Europe), 2010 IEEE PES, Oct. 2010, pp. 1–6.
- [10] M. Singh, P. Kumar, and I. Kar, “Implementation of vehicle to grid infrastructure using fuzzy logic controller,” IEEE Trans. Smart Grid, vol. 3, no. 1, pp. 565–577, Mar. 2012.
- [11] S.Deilami, A.S.Masoum, P.S.Moses, and M. A.S.Masoum, “Realtime coordination of plug-in electric vehicle charging in smart grids to minimize power losses and improve voltage profile,” IEEE Trans. Smart Grid, vol. 2, no. 3, pp. 456–467, Sep. 2011.
- [12] M. Singh, P. Kumar, and I. Kar, “A model of electric vehicle charging station compatibles with vehicle to grid scenario,” in Proc. 2012 IEEE Int. Electric Vehicle Conference (IEVC), Mar. 2012, pp. 1–7, doi: 10.1109/IEVC.2012.6183223.
- [13] M. Singh, P. Kumar, and I. Kar, “Designing a multi charging station for electric vehicles and its utilization for the grid support,” in IEEE PES General Meeting, Jul. 2012, pp. 1–8, doi: 10.1109/PESGM.2012.6344868.
- [14] Matlab SIMPower Simulation [Online]. Available: <http://www.mathworks.com>
- [15] M. Chakravorty and D. Das, “Voltage stability analysis of radial distribution networks,” Electrical Power and Energy Systems, vol. 23, pp. 129–135, 2001.